

# Telemecanique ABL 7CEM240●●

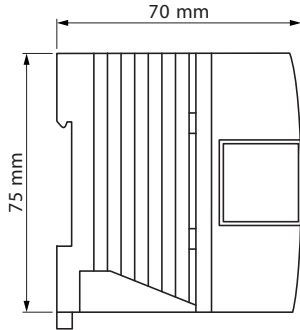

ABL 7CEM24003

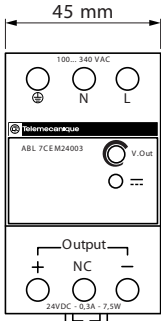
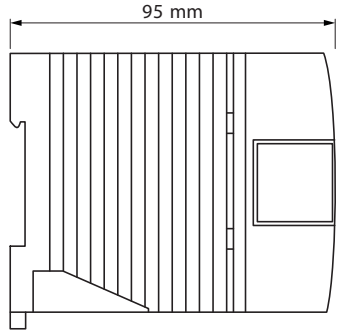

ABL 7CEM24006 □  
ABL 7CEM24012

2-M4 or 2-Ø4.5

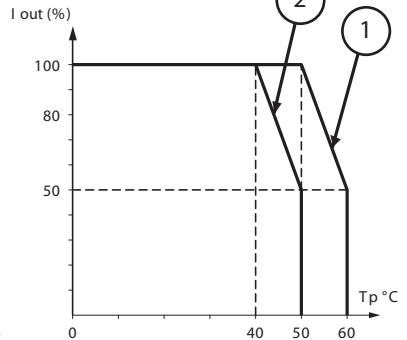
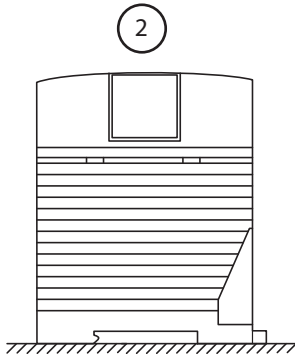
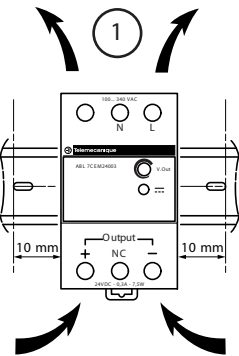
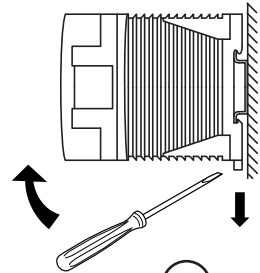
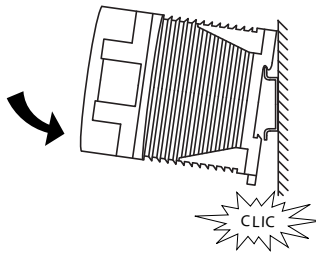
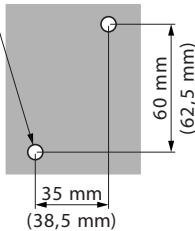

## ⚠ DANGER / WARNUNG / PELIGRO / PERICOLO / PERIGO

**HAZARDOUS VOLTAGE**  
Disconnect all power before servicing equipment.  
**Electric shock will result in death or serious injury**

**TENSION DANGEREUSE**  
Coupez l'alimentation avant de travailler sur cet appareil.  
**Une électrocution entraînera la mort ou des blessures graves.**

**GEFÄHRLICHE SPANNUNG**  
Vor dem Arbeiten an dem Gerät dessen Stromversorgung abschalten.  
**Elektrischer Schlag mit Lebensgefahr bzw. schweren Verletzungen.**

**TENSIÓN PELIGROSA**  
Desconecte toda alimentación Antes de realizar el servicio.  
**Una descarga eléctrica podría provocar la muerte o lesiones serias.**

**TENSION PERICOLOSA**  
Scollegare l'apparecchio dalla presa di corrente prima di qualsiasi intervento.  
**Una scarica elettrica potrebbe causare la morte o gravi lesioni.**

**TENSÃO PERIGOSA**  
Desligue a alimentação antes de trabalhar neste aparelho.  
**Uma electrocussão ocasionará a morte ou ferimentos graves.**

**Schneider**  
 **Electric**

W9 1489456 01 11 A01

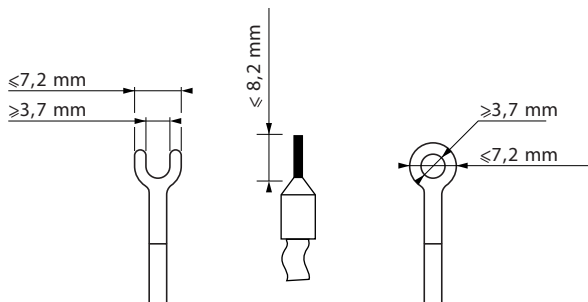
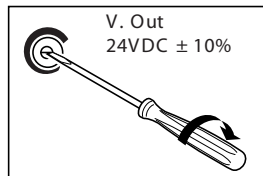
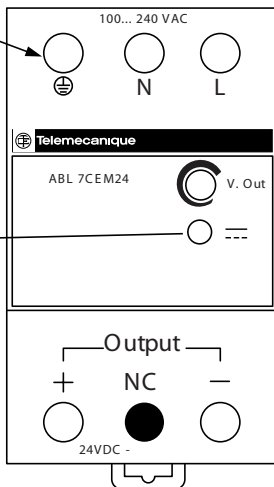
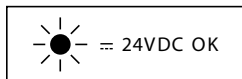
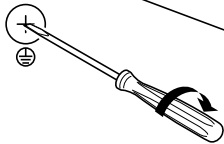

ABL7CEM						
mm <sup>2</sup>	0,75...2,5	0,75...2,5	0,75...4	0,75...2,5	0,75...2,5	0,75...2,5
AWG	22...14	22...14	22...12	22...14	22...14	22...14
				Nm	0,8	
Ø 3,5		C		lb-in	7	

Pour USA et Canada: Utiliser câble en cuivre 60° uniquement.couple de serrage :0,8Nm.	For USA and Canada: use minimum 60° wire,use copper wire only.Terminal torque :0,8Nm.	Für die USA und Kanada: Nur Kupferkabel 60° verwenden Anziehdrehmoment: 0,8 Nm
Para EE.UU. y Canadá: Utilícese cable de cobre 60° Únicamente par de apretado: 0,8 Nm	Per Stati Uniti e Canada : Utilizzare cavo in rame 60° unicamente coppia di serraggio : 0,8 Nm	Para os Estados Unidos e para o Canadá: Utilizar cabo em cobre 60° unicamente, binário ou força de aperto : 0,8Nm

OK

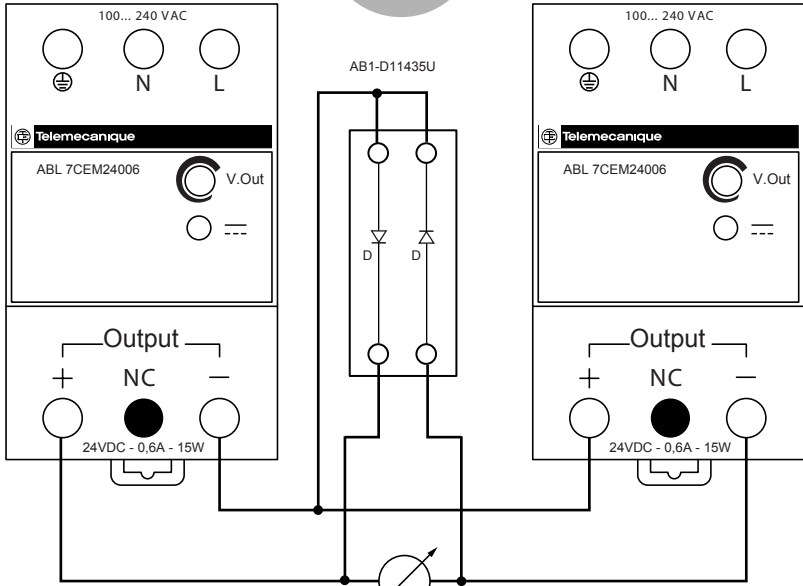

2X 24 VDC / I out

D=Shottky diode 2A/100V

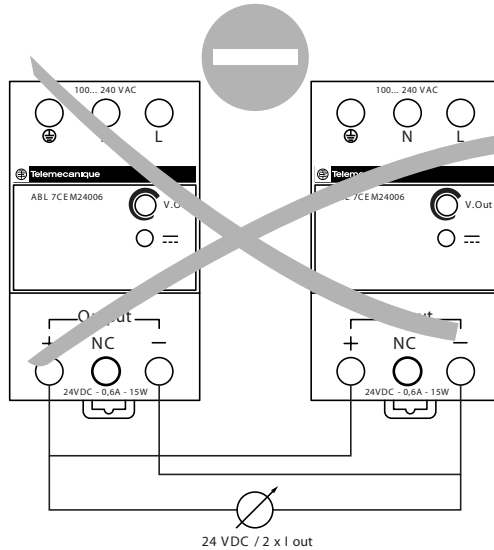

24 VDC / 2 x I out

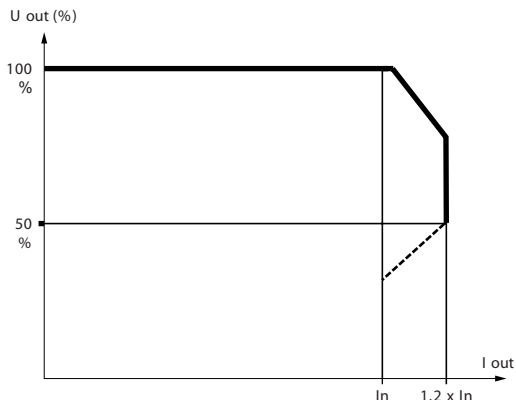

### Safety Instructions

There is a dangerous voltage inside the ABL-7. Any utilisation or intervention which does not comply with codes of practice can result in death, serious physical injury or irreparable damage to equipment.

Before any intervention, the main circuit breaker must be open and secured against any inadvertent closing.

#### ATTENTION

The unit must be opened by qualified personnel only. Do not allow entry of liquids or foreign objects into the ABL-7

### Consignes De Sécurité

Présence de tension dangereuse à l'intérieur de ABL-7. Toute utilisation et/ou intervention contraires aux règles de l'art peuvent conduire à la mort, à des lésions corporelles graves ou à des dommages matériels importants.

Avant toute intervention, le disjoncteur principal doit être ouvert et assuré contre toute refermeture intempestive.

#### ATTENTION

L'appareil ne doit être ouvert que par du personnel initié. Ne pas laisser pénétrer de liquide ou d'objets étrangers à l'intérieur de ABL-7.

### Sicherheitsanweisungen

Gefährliche Spannung im Inneren des ABL-7. Unsachgemäßer Umgang bzw. Eingriffe sind lebensgefährlich und können schwere Schäden an Personen und Material verursachen.

Vor dem Arbeiten das Gerät unbedingt am Hauptschalter abschalten und diesen sichern, um ein ungewolltes Wiedereinschalten zu verhindern.

#### ACHTUNG

Das Wiedereinschalten darf nur durch eine qualifizierte Person erfolgen. Keine Flüssigkeit oder Fremdkörper ins Innere des ABL-7 gelangen lassen.

### Consignas de seguridad

Presencia de tensión peligrosa al interior del ABL-7. Toda utilización y/o intervención contrarias a las reglas del arte pueden provocar la muerte, lesiones corporales graves o daños materiales importantes.

Antes de cualquier intervención debe abrirse el disyuntor principal, asegurándolo contra cualquier cierre intempestivo.

#### ATENCIÓN

El aparato sólo debe ser abierto por el personal capacitado.

No dejar que ingresen líquidos ni objetos extraños al interior del ABL-7.

### Avvertenze di sicurezza

Presenza tensione pericolosa all'interno dell'ABL-7. Qualsiasi impiego e/o intervento contrari alle norme possono essere causa di morte, di gravi lesioni corporali o di notevoli danni materiali.

Il disgiuntore principale deve essere aperto e assicurato contro l'eventualità di qualsiasi richiusura indesiderata prima di ogni intervento.

#### ATTENZIONE

L'apparecchio deve essere aperto solo da personale qualificato. Non lasciare penetrare alcun liquido o oggetto estraneo all'interno dell'ABL-7.

### Instruções de segurança

Presença de tensão perigosa no interior do ABL-7. Qualquer utilização e/ou intervenção contrária às regras da arte pode ocasionar a morte, lesões corpóreas graves ou danos materiais importantes.

Antes de qualquer intervenção, o disjuntor principal deve ser aberto e assegurado contra qualquer fecho intempestivo.

#### ATENÇÃO

O aparelho só deve ser aberto por um pessoal experiente.

Não deixar penetrar líquidos ou objectos estranhos para dentro do ABL-7.