

DIMENSIONS (Unit: mm in)

The CAD data in the dimensions can be downloaded from the SUNX website: <http://www.sunx.com>

CX-41□ Sensor

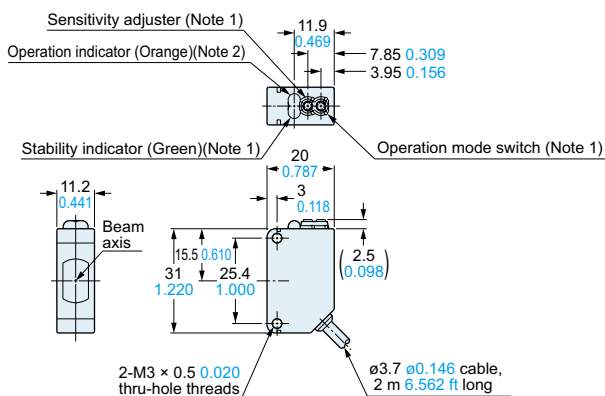

Notes: 1) Not incorporated on the emitter.
2) It is the power indicator (green) on the emitter.

CX-41□-Z Sensor

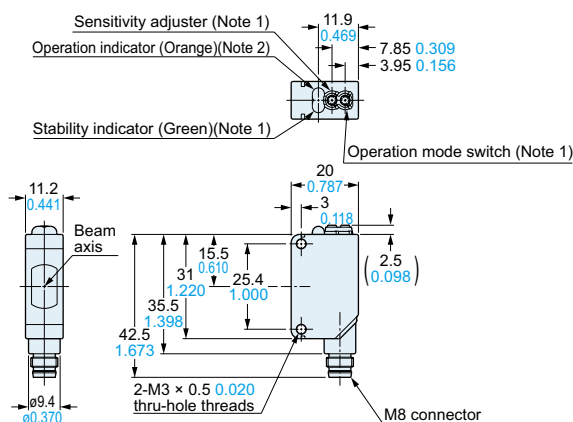

Notes: 1) Not incorporated on the emitter.
2) It is the power indicator (green) on the emitter.

CX-41□-J Sensor

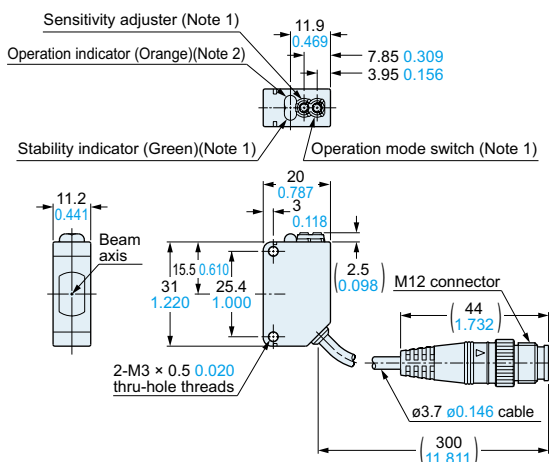

Notes: 1) Not incorporated on the emitter.
2) It is the power indicator (green) on the emitter.

CX-49□ CX-48□ CX-42□ Sensor

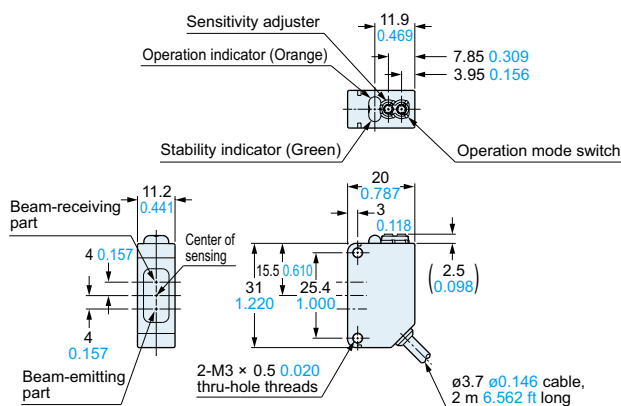

CX-49□-Z CX-48□-Z CX-42□-Z Sensor

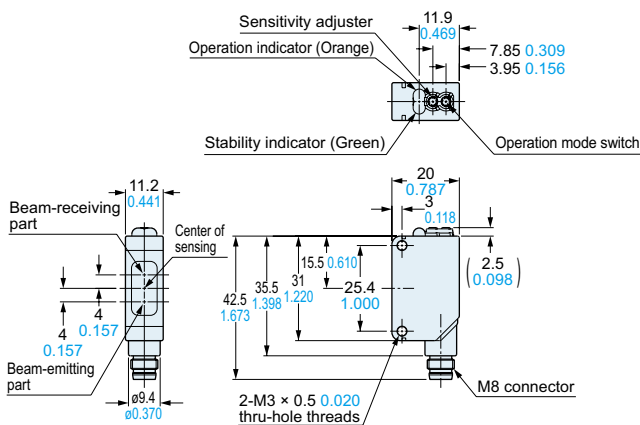

CX-49□-J CX-48□-J CX-42□-J Sensor

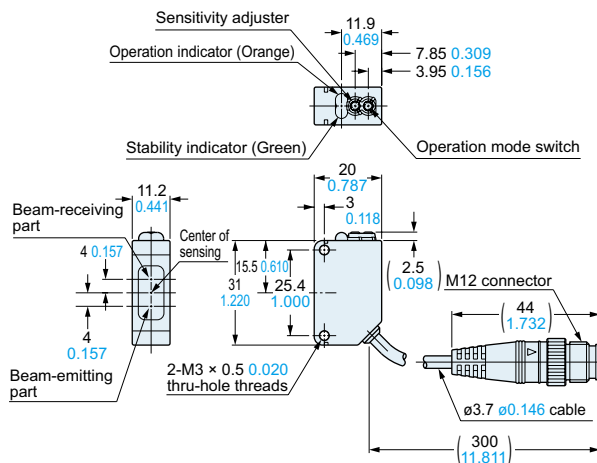

FIBER SENSORS

LASER SENSORS

PHOTO-ELECTRIC SENSORS

MICRO PHOTO-ELECTRIC SENSORS

AREA SENSORS

SAFETY COMPONENTS

PRESSURE SENSORS

INDUCTIVE PROXIMITY SENSORS

PARTICULAR USE SENSORS

SENSOR OPTIONS

WIRE-SAVING SYSTEMS

MEASUREMENT SENSORS

STATIC CONTROL DEVICES

LASER MARKERS

Selection Guide

Amplifier Built-in

CX-400

EX-10

EX-20

EX-30

EX-40

EQ-30

EQ-500

MQ-W

RX-LS200

RX

CY

M18

PX-2

Power Supply Built-in

NX5

VF

Other Products

DIMENSIONS (Unit: mm in)

The CAD data in the dimensions can be downloaded from the SUNX website: <http://www.sunx.com>

- FIBER SENSORS
- LASER SENSORS
- PHOTO-ELECTRIC SENSORS
- MICRO PHOTO-ELECTRIC SENSORS
- AREA SENSORS
- SAFETY COMPONENTS
- PRESSURE SENSORS
- INDUCTIVE PROXIMITY SENSORS
- PARTICULAR USE SENSORS
- SENSOR OPTIONS
- WIRE-SAVING SYSTEMS
- MEASUREMENT SENSORS
- STATIC CONTROL DEVICES
- LASER MARKERS
- Selection Guide
- Amplifier Built-in
- CX-400**
- EX-10
- EX-20
- EX-30
- EX-40
- EQ-30
- EQ-500
- MQ-W
- RX-LS200
- RX
- CY
- M18
- PX-2
- Power Supply Built-in
- NX5
- VF
- Other Products

CX-44□ Sensor

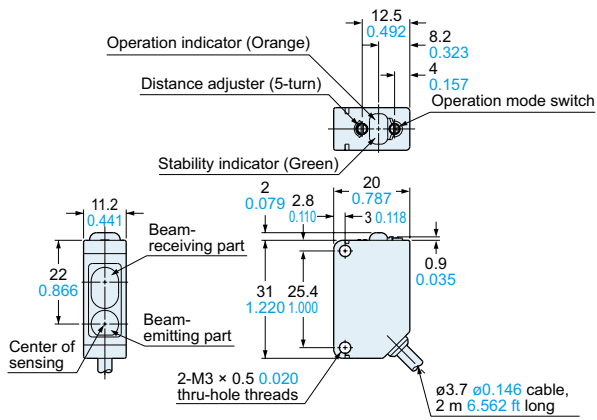

CX-44□-Z Sensor

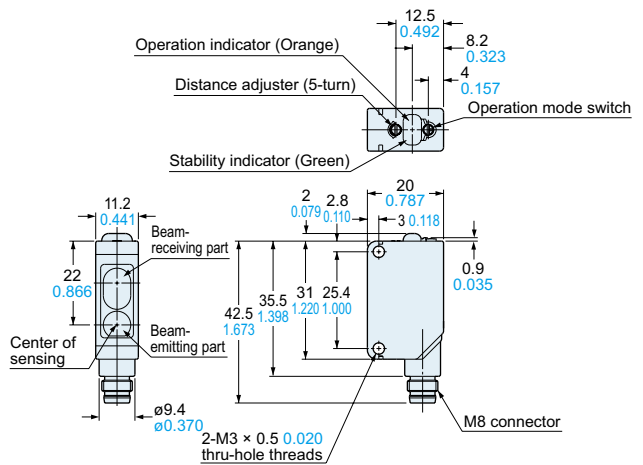

RF-230 Reflector (Accessory for the retroreflective type sensor)

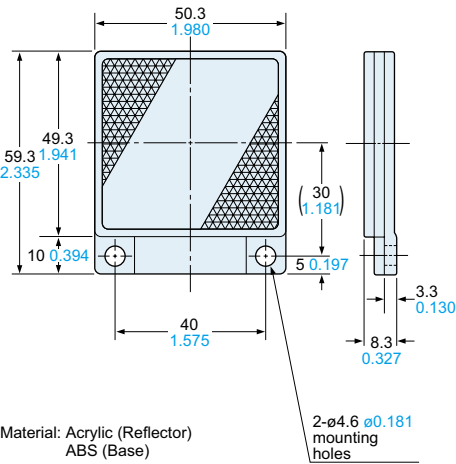

RF-220 Reflector (Optional)

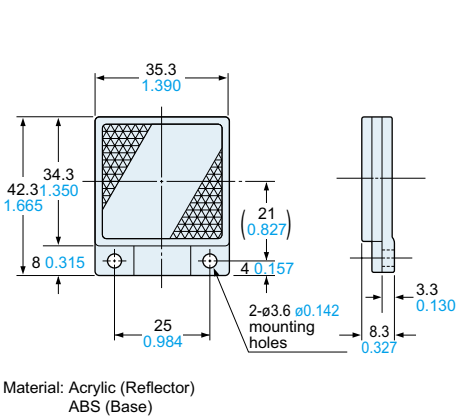

RF-210 Reflector (Optional)

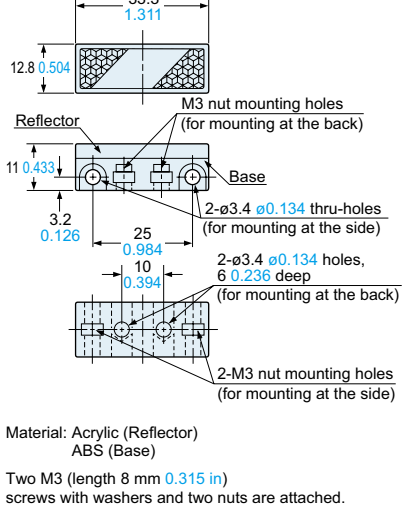

RF-11 Reflective tape (Optional)

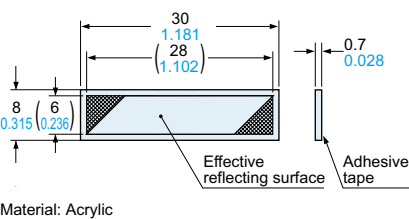

RF-12 Reflective tape (Optional)

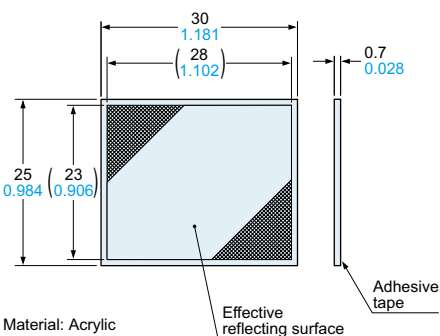

RF-13 Reflective tape (Optional)

