

1

SM1P... z zestawkami bocznymi

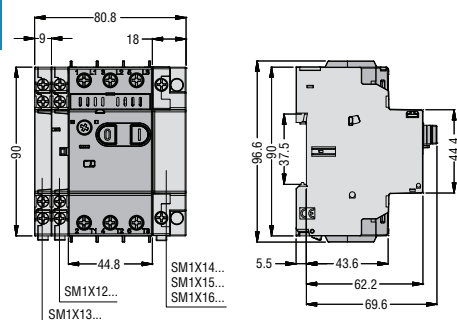

SM1R... z zestawkami bocznymi

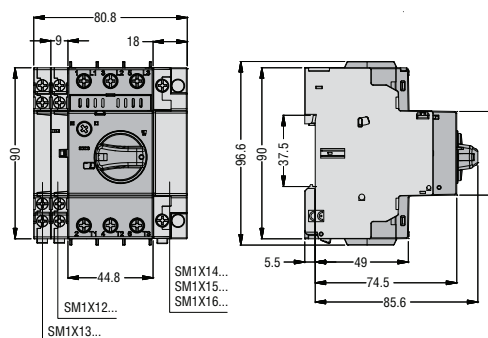

SM1P... ze stycznikami BG... i złączem SM1X30 40P

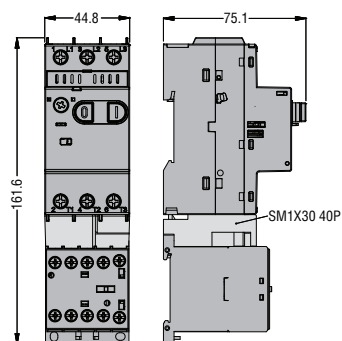

SM1P... ze stycznikami BF09 A...BF25 A... i złączem SM1X31 41P

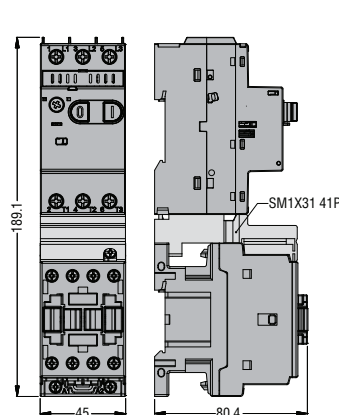

SM1P... ze stycznikami BF26 A...BF38 A... i złączem SM1X32 41P

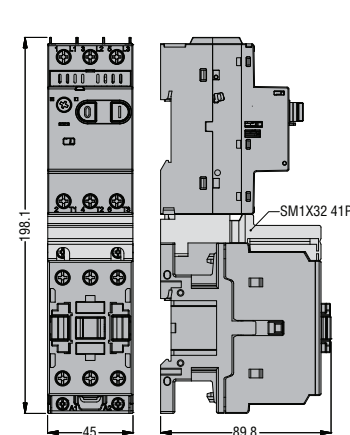

SM1R... ze stycznikami BG... i złączem SM1X30 40R

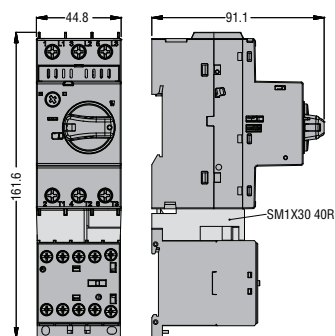

SM1R... ze stycznikami BF09 A...BF25 A... i złączem SM1X31 41R

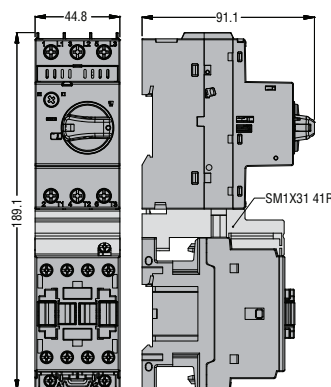

SM1R... ze stycznikami BF09 D...BF25 D... BF09 L...BF25 L... i złączem SM1X31 42R

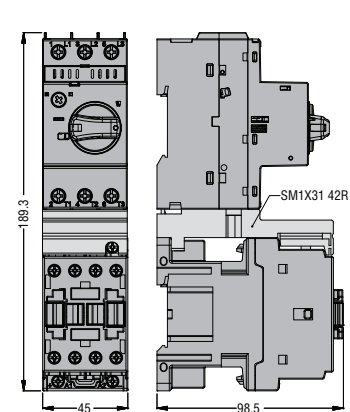

SM1R... ze stycznikami BF26 A...BF38 A... i złączem SM1X32 41R

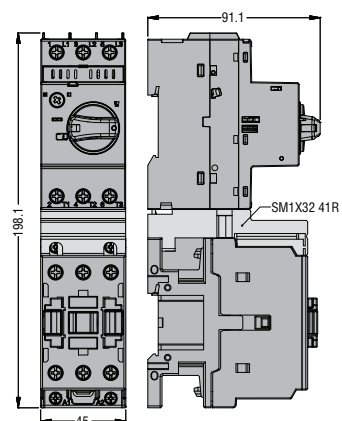

SM1R... z pokrętkiem do wersji ze sprzęgłem SM1X18 200R lub SM1X18B 200R

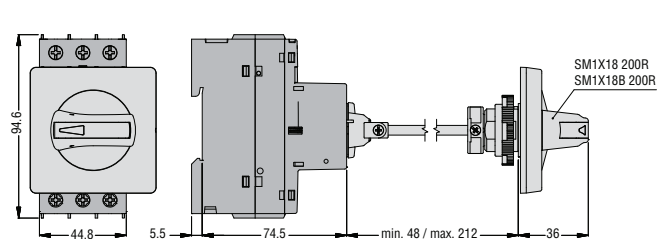

Szyny zbiorcze montowane z **SM1...**
bez zestyków pomocniczych

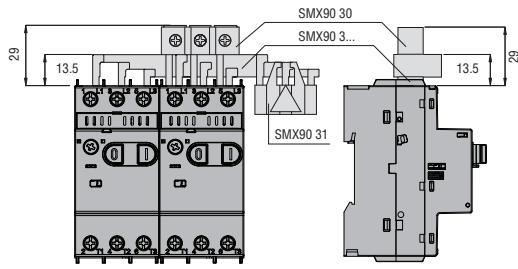

Szyny zbiorcze montowane z **SM1...**
z zestykami pomocniczymi **SMX12...** lub **SMX13 11**

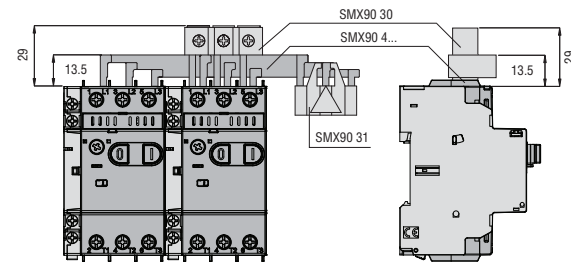

Szyny zasilające – odstęp 54mm
SMX90 42 - SMX90 43 - SMX90 44 - SMX90 45

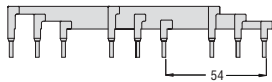

Szyny zasilające – odstęp 45mm
SMX90 32 - SMX90 33 - SMX90 34 - SMX90 35

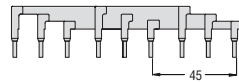

Zaciski zasilające do szyn
zbiorczych **SMX90 30**



Pokrywa zabezpieczająca
SMX90 31



Obudowy **SM1Z17 01P** i **SM1Z17 02P**

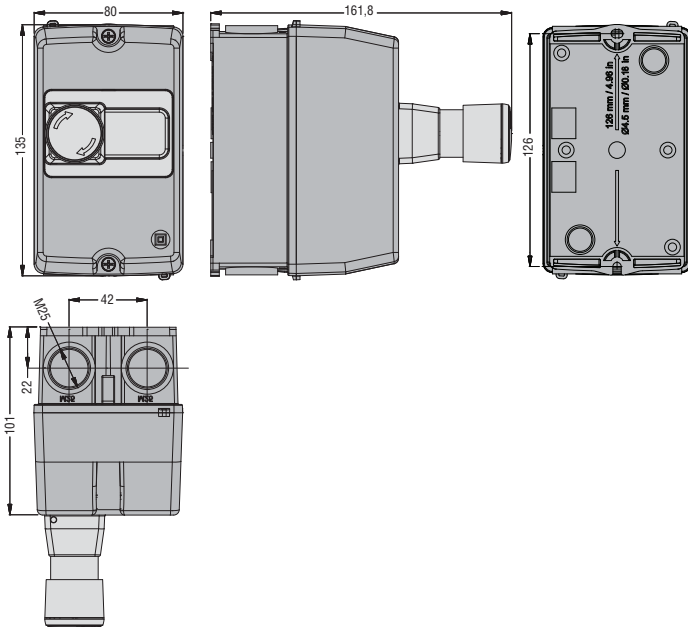

Obudowy **SM1Z17 05P**

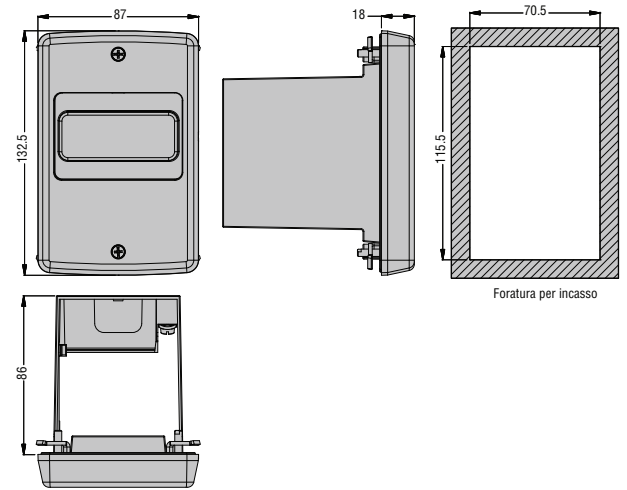

Obudowy **SM1Z17 11P** i **SM1Z17 12P**

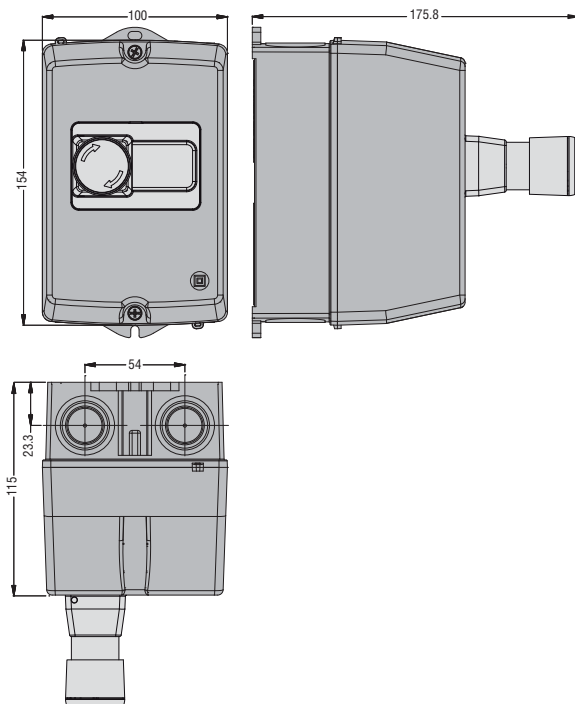

Obudowy **SM1Z17 15R** i **SM1Z17 10R**

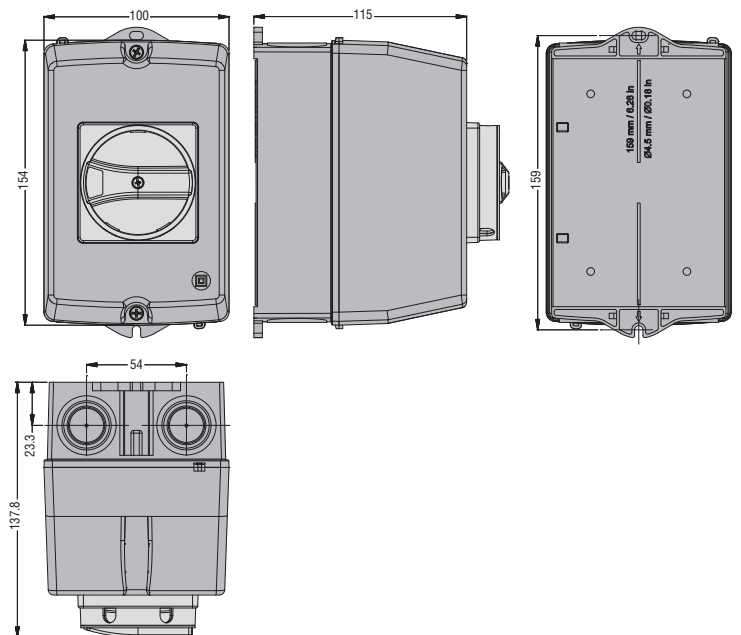

1

SM2... z zestykami bocznymi

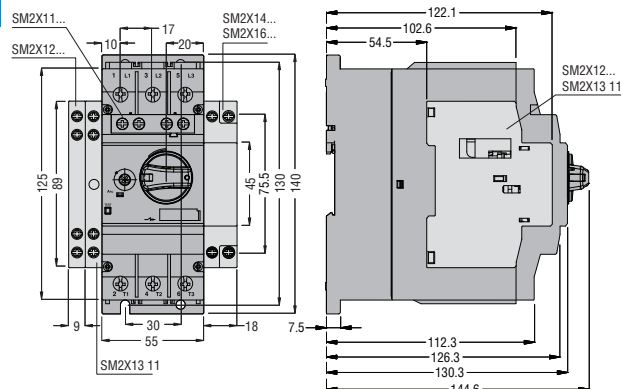

SM3... z zestykami bocznymi

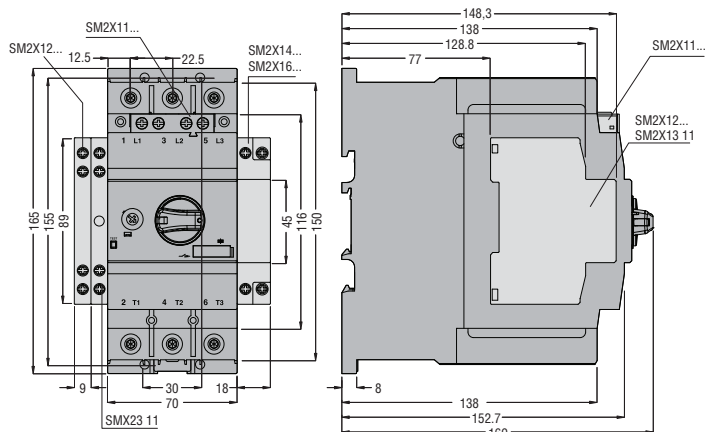

SM2... i SM3... z pokrętkiem do wersji ze sprzęgłem SM1X18 200R lub SM1X18B 200R

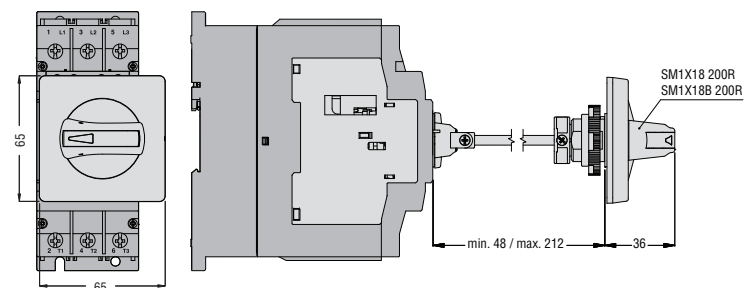

Schematy elektryczne

WYŁĄCZNIKI SILNIKOWE SM1P...

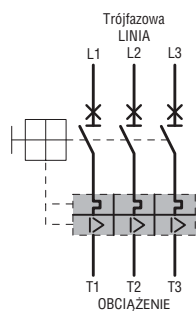

SM1R... - SM2R... - SM3R...

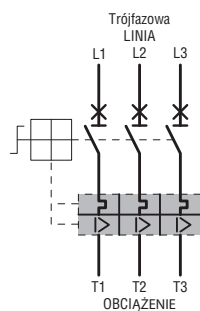

SM1RM...

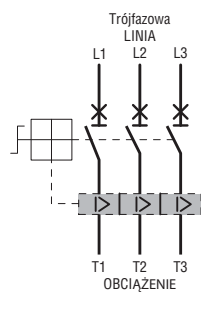

WYŁĄCZNIKI SM1PF...

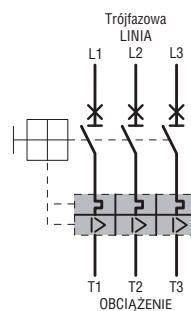

Dla wszystkich wyłączników silnikowych

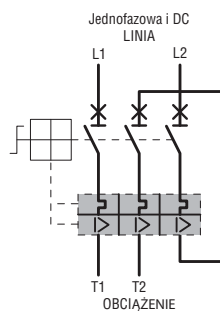

AKCESORIA

Do SM1...

Zestyki montowane z przodu

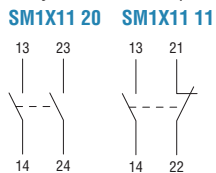

Zestyki montowane z boku

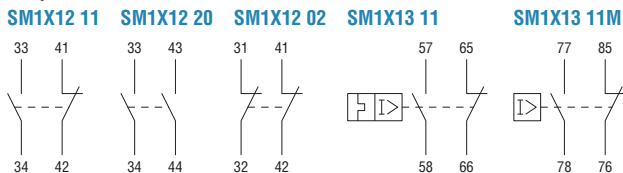

Wywzłacz podnapięciowy SM1X14...

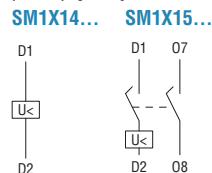

Wywzłacz wzrostowy SM1X16...



Do SM2R... i SM3R

Zestyki montowane z przodu

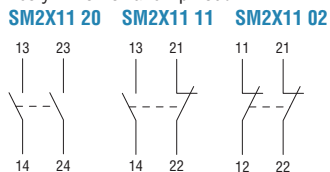

Zestyki montowane z boku

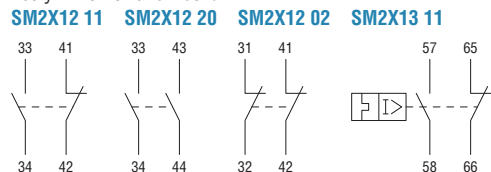

Wywzłacz podnapięciowy SM2X14...



Wywzłacz wzrostowy SM2X16...

