

FEATURES

- **Forcibly guide contact structure** (EN50205 Class A TÜV recognized)
- **Slim profile (mm inch)**
Compact size with slim profile relay reduces substrate size.
[4-pole type]40 (L)×13 (W)×24 (H)
1.575 (L)×.512 (W)×.945 (H)
[6-pole type]50 (L)×13 (W)×24 (H)
1.969 (L)×.512 (W)×.945 (H)
- **Built-in LED indication type available**
Built-in LED eliminates need for design and mounting of separate LED circuit. This cuts costs and saves labor.
- **Fast response time is achieved (8 ms or less)**
Circuit is quickly opened to ensure safety.
- **High shock resistance** (Functional: Min. 200m/s²)
Improved anti-shock properties meaning that the relay can be safely used in high shock and vibration environments such as in machine tools and other factory equipment.

- PC board sockets also available (4 and 6-poles)
- Lineup also includes DIN terminal socket with finger protect construction (4 and 6-poles)

TYPICAL APPLICATIONS

- Machine tools
- Robots
- Safety PLCs
- Circuits with stringent safety standard requirements such as those in motor vehicle production equipment.

SPECIFICATIONS

Contact

Item		4 poles	6 poles
Contact arrangement		2 Form A/2 Form B 3 Form A/1 Form B	4 Form A/2 Form B 5 Form A/1 Form B 3 Form A/3 Form B
Initial contact resistance, max. (By voltage drop 6 V DC 1 A)		100 mΩ	
Contact material		Gold-flashed AgSnO ₂ type	
Rating (resistive load)	Nominal switching capacity	6 A 250 V AC, 6 A 30 V DC	
	Max. switching power	1,500 VA, 180 W	
	Max. switching voltage	250 V AC, 30 V DC	
	Max. switching current	6 A (Reduce by 0.1 A/°C for temperatures 70 to 85°C.)	
	Min. switching capacity (Reference value) #1	1 mA 5 V DC	
Expected life (min. operations)	Mechanical (at 180 times/min.)	10 ⁷	
	Electrical	250 V AC 6 A resistive load: 10 ⁵ (at 20 times/min.)	
		30 V DC 6 A resistive load: 10 ⁵ (at 20 times/min.)	
		250 V AC 1 A resistive load: 5×10 ⁵ (at 30 times/min.)	
		30 V DC 1 A resistive load: 5×10 ⁵ (at 30 times/min.)	
		[AC 15] 240 V AC 2 A inductive load: 10 ⁵ (at 20 times/min., cosφ = 0.3)	
[DC 13] 24 V DC 1 A inductive load: 10 ⁵ (at 20 times/min., L/R = 48 ms)			

#1 This value can change due to the switching frequency, environmental conditions, and desired reliability level, therefore it is recommended to check this with the actual load.

Coil

	4 poles	6 poles
		2 Form A/2 Form B 3 Form A/1 Form B
Nominal operating power	360 mW	500 mW

Characteristics (at 20°C 68°F)

Item	4 poles		6 poles	
	2 Form A/2 Form B 3 Form A/1 Form B		4 Form A/2 Form B 5 Form A/1 Form B 3 Form A/3 Form B	
Max. operating speed	20 times/min. (at nominal voltage)			
Initial insulation resistance*1	Min. 1,000 MΩ at 500 V DC			
Initial breakdown voltage*2	Between open contacts	1,500 Vrms for 1 min.		
	Between contact sets	2,500 Vrms for 1 min.: 7-8/9-10	2,500 Vrms for 1 min.: 7-8/11-12 9-10/13-14 11-12/13-14	
		4,000 Vrms for 1 min.: 3-4/5-6 3-4/7-8 5-6/9-10	4,000 Vrms for 1 min.: 3-4/5-6 3-4/7-8 5-6/9-10 7-8/9-10	
	Between contact and coil	4,000 Vrms for 1 min.		
Operate time (at nominal voltage)	Max. 20 ms*3			
Response time*4 (without diode) (at nominal voltage)	Max. 8 ms*3			
Release time (without diode) (at nominal voltage)	Max. 20 ms*3			
Shock resistance	Functional*5	Min. 200 m/s ²		
	Destructive*6	Min. 1,000 m/s ²		
Vibration resistance	Functional*7	10 to 55 Hz at double amplitude of 1.5 mm		
	Destructive	10 to 55 Hz at double amplitude of 1.5 mm		
Conditions for operation, transport and storage*8 (Not freezing and condensing at low temperature)	Ambient temp.	-40°C to +85°C -40°F to +185°F		
	Humidity	5 to 85% R.H.		
Unit weight	Approx. 20 g	Approx. .71 oz	Approx. 23 g	Approx. .81 oz

• Outline of performance [Socket for PC board/DIN terminal socket]

Max. carrying current	6 A (Reduce by 0.1 A/°C for temperatures 70 to 85°C.)
Initial breakdown voltage	Between each terminal: 2,500 Vrms for 1 min. (Detection current: 10mA)
Initial insulation resistance*1	Min. 1,000 MΩ at 500V DC

Remarks

- *1 Measurement at same location as "Initial breakdown voltage" section
- *2 Detection current: 10mA
- *3 Excluding contact bounce time
- *4 Response time is the time after the coil voltage turns off until the time when "a" contact turns off.
- *5 Half-wave pulse of sine wave: 11ms; detection time: 10μs
- *6 Half-wave pulse of sine wave: 6ms
- *7 Detection time: 10μs
- *8 Refer to "NOTES" on page 9, 7. Usage, transport and storage conditions.

ORDERING INFORMATION

Ex. SF S - - -

Product name	Contact arrangement	Operation indication	Coil voltage
Slim type	2: 2 Form A/2 Form B 3: 3 Form A/1 Form B 4: 4 Form A/2 Form B 5: 5 Form A/1 Form B 6: 3 Form A/3 Form B	Nil: Without LED indication L: With LED indication	DC12, 18, 21, 24, 48V

Note: Standard packing: Carton 50 pcs. Case 200 pcs. (Accessories: Carton 10 pcs. Case 100 pcs.)
Please inquire about other coil voltages.

TYPES**1. Relay**

Contact arrangement		Nominal voltage	Without LED indication	With LED indication
			Part No.	Part No.
4 poles	2 Form A/2 Form B	12 V DC	SFS2-DC12V	SFS2-L-DC12V
		18 V DC	SFS2-DC18V	SFS2-L-DC18V
		21 V DC	SFS2-DC21V	SFS2-L-DC21V
		24 V DC	SFS2-DC24V	SFS2-L-DC24V
		48 V DC	SFS2-DC48V	SFS2-L-DC48V
	3 Form A/1 Form B	12 V DC	SFS3-DC12V	SFS3-L-DC12V
		18 V DC	SFS3-DC18V	SFS3-L-DC18V
		21 V DC	SFS3-DC21V	SFS3-L-DC21V
		24 V DC	SFS3-DC24V	SFS3-L-DC24V
		48 V DC	SFS3-DC48V	SFS3-L-DC48V
6 poles	4 Form A/2 Form B	12 V DC	SFS4-DC12V	SFS4-L-DC12V
		18 V DC	SFS4-DC18V	SFS4-L-DC18V
		21 V DC	SFS4-DC21V	SFS4-L-DC21V
		24 V DC	SFS4-DC24V	SFS4-L-DC24V
		48 V DC	SFS4-DC48V	SFS4-L-DC48V
	5 Form A/1 Form B	12 V DC	SFS5-DC12V	SFS5-L-DC12V
		18 V DC	SFS5-DC18V	SFS5-L-DC18V
		21 V DC	SFS5-DC21V	SFS5-L-DC21V
		24 V DC	SFS5-DC24V	SFS5-L-DC24V
		48 V DC	SFS5-DC48V	SFS5-L-DC48V
	3 Form A/3 Form B	12 V DC	SFS6-DC12V	SFS6-L-DC12V
		18 V DC	SFS6-DC18V	SFS6-L-DC18V
		21 V DC	SFS6-DC21V	SFS6-L-DC21V
		24 V DC	SFS6-DC24V	SFS6-L-DC24V
		48 V DC	SFS6-DC48V	SFS6-L-DC48V

2. Accessories

Type	No. of poles	Part No.
PC board sockets	4 poles	SFS4-PS
	6 poles	SFS6-PS
DIN terminal socket	4 poles	SFS4-SFD
	6 poles	SFS6-SFD

COIL DATA (at 20°C 68°F)

Contact arrangement		Nominal voltage, V DC	Pick-up voltage, V DC (max.) (initial)	Drop-out voltage, V DC (min.) (initial)	Nominal operating current, mA ($\pm 10\%$)	Coil resistance Ω ($\pm 10\%$)	Nominal operating power, mW	Max. allowable voltage, V DC
4 poles	2 Form A/2 Form B	12	9	1.2	30	400	Approx. 360	13.2
		18	13.5	1.8	20	900		19.8
		21	15.75	2.1	17.1	1,225		23.1
		24	18	2.4	15	1,600		26.4
		48	36	4.8	7.5	6,400		52.8
	3 Form A/1 Form B	12	9	1.2	30	400		13.2
		18	13.5	1.8	20	900		19.8
		21	15.75	2.1	17.1	1,225		23.1
		24	18	2.4	15	1,600		26.4
		48	36	4.8	7.5	6,400		52.8
6 poles	4 Form A/2 Form B	12	9	1.2	41.7	288	Approx. 500	13.2
		18	13.5	1.8	27.8	648		19.8
		21	15.75	2.1	23.8	882		23.1
		24	18	2.4	20.8	1,152		26.4
		48	36	4.8	10.4	4,608		52.8
	5 Form A/1 Form B	12	9	1.2	41.7	288		13.2
		18	13.5	1.8	27.8	648		19.8
		21	15.75	2.1	23.8	882		23.1
		24	18	2.4	20.8	1,152		26.4
		48	36	4.8	10.4	4,608		52.8
	3 Form A/3 Form B	12	9	1.2	41.7	288		13.2
		18	13.5	1.8	27.8	648		19.8
		21	15.75	2.1	23.8	882		23.1
		24	18	2.4	20.8	1,152		26.4
		48	36	4.8	10.4	4,608		52.8

Note: The nominal operating current of the LED indication type increases approximately 2 mA because of the light emitting diode display.

DIMENSIONS mm inch

Download [CAD Data](#) from our Web site.

1. 4 poles (2 Form A/2 Form B, 3 Form A/1 Form B)

[CAD Data](#)

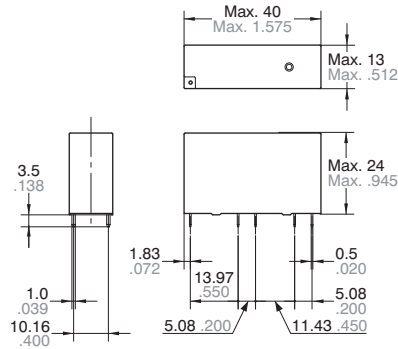
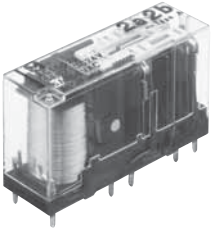

PC board pattern (Bottom view)

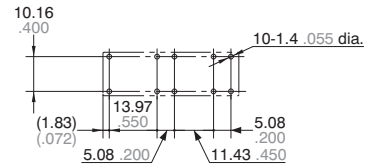

Tolerance: $\pm 0.1 \pm .004$

General tolerance: $\pm 0.3 \pm .012$

Schematic (Bottom view)

Standard

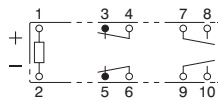

(2 Form A/2 Form B)

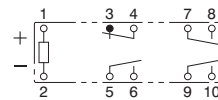

(3 Form A/1 Form B)

With LED indication

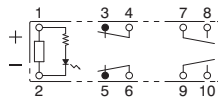

(2 Form A/2 Form B)

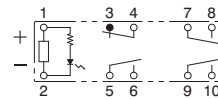

(3 Form A/1 Form B)

2. 6 poles (4 Form A/2 Form B, 5 Form A/1 Form B, 3 Form A/3 Form B)

[CAD Data](#)

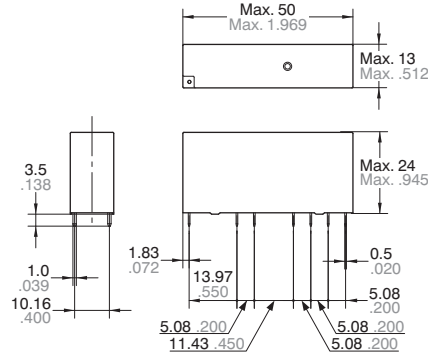
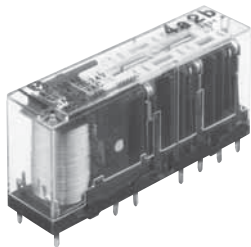

PC board pattern (Bottom view)

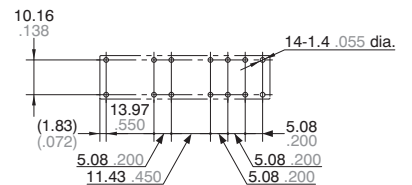

Tolerance: $\pm 0.1 \pm .004$

General tolerance: $\pm 0.3 \pm .012$

Schematic (Bottom view)

Standard

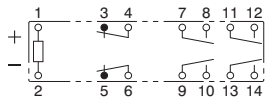

(4 Form A/2 Form B)

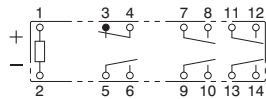

(5 Form A/1 Form B)

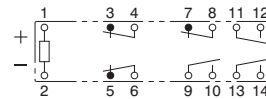

(3 Form A/3 Form B)

With LED indication

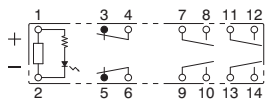

(4 Form A/2 Form B)

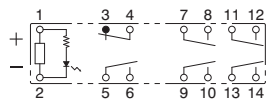

(5 Form A/1 Form B)

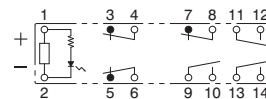

(3 Form A/3 Form B)

3. PC board sockets (4 poles)

mm inch

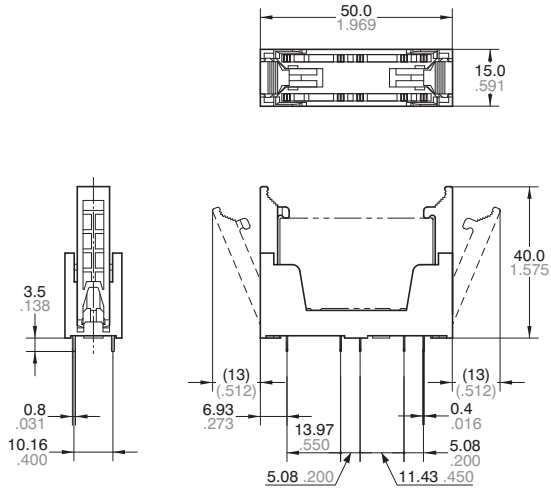
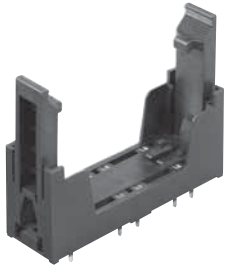

PC board pattern (Bottom view)

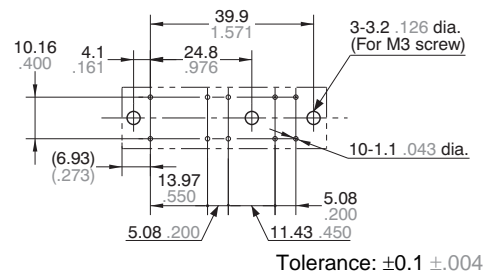

Tolerance: $\pm 0.1 \pm 0.04$

General tolerance: $\pm 0.3 \pm 0.012$

Schematic (Bottom view)

Standard

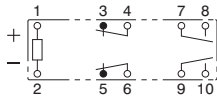

(When 2 Form A/2 Form B mounted)

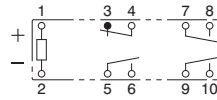

(When 3 Form A/1 Form B mounted)

With LED indication

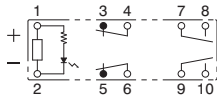

(When 2 Form A/2 Form B mounted)

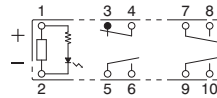

(When 3 Form A/1 Form B mounted)

4. PC board sockets (6 poles)

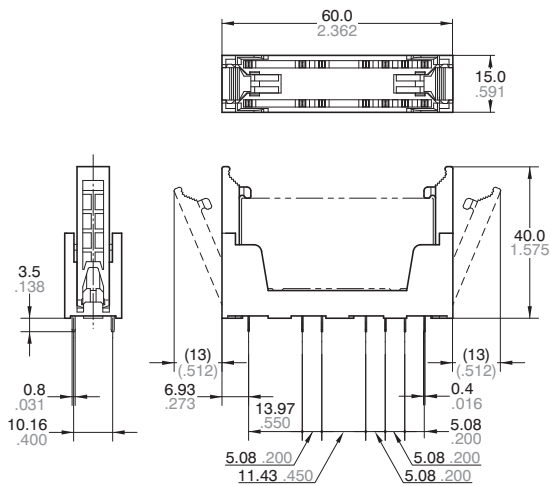
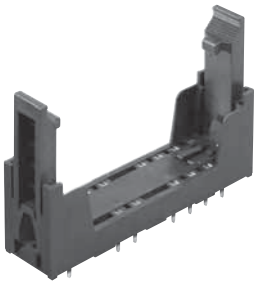

PC board pattern (Bottom view)

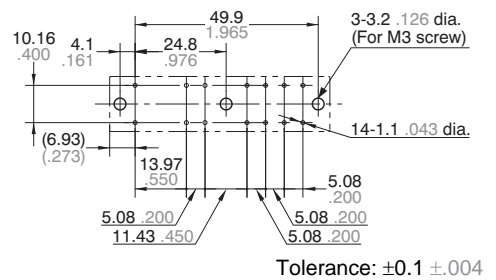

Tolerance: $\pm 0.1 \pm 0.04$

General tolerance: $\pm 0.3 \pm 0.012$

Schematic (Bottom view)

Standard

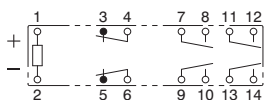

(When 4 Form A/2 Form B mounted)

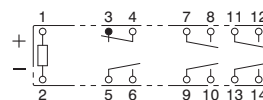

(When 5 Form A/1 Form B mounted)

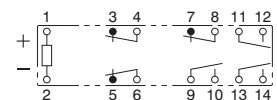

(When 3 Form A/3 Form B mounted)

With LED indication

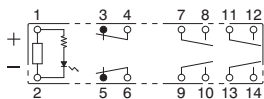

(When 4 Form A/2 Form B mounted)

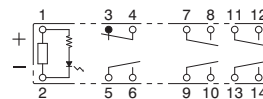

(When 5 Form A/1 Form B mounted)

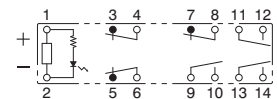

(When 3 Form A/3 Form B mounted)

5. DIN terminal socket (4 poles)

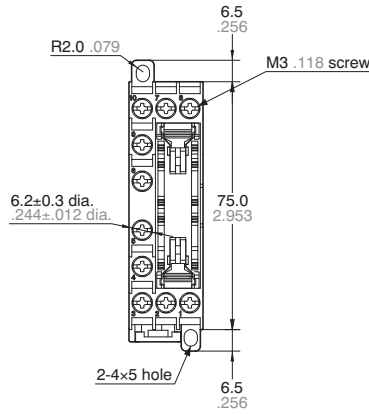
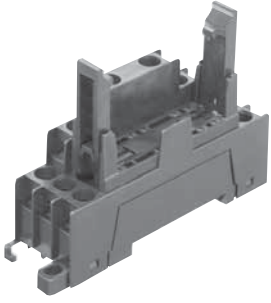

Mounting hole dimensions

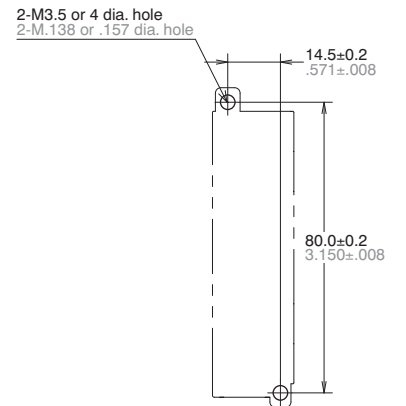

Tolerance: $\pm 0.1 \pm .004$

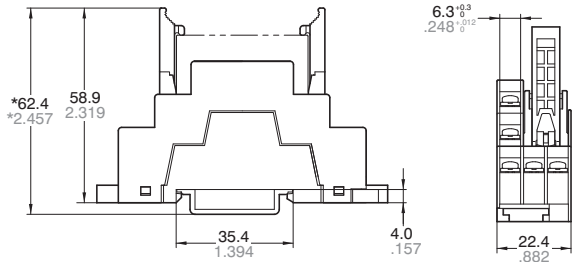

General tolerance: $\pm 0.5 \pm .020$

Schematic (Top view)

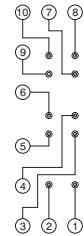

* Reference value (when using DIN rail ATA48011)

Note: Round terminals cannot be used with DIN terminal sockets.

6. DIN terminal socket (6 poles)

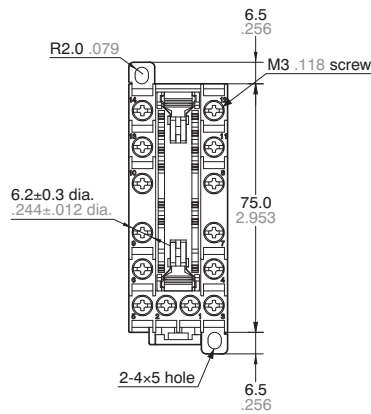
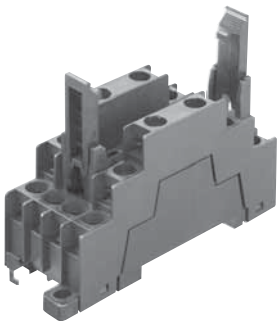

Mounting hole dimensions

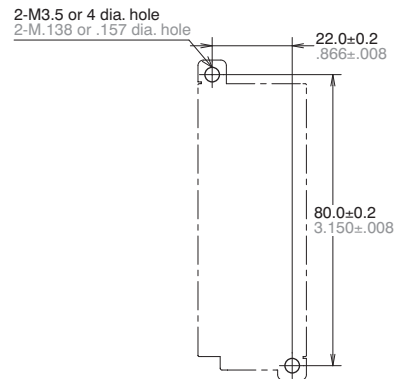

Tolerance: $\pm 0.1 \pm .004$

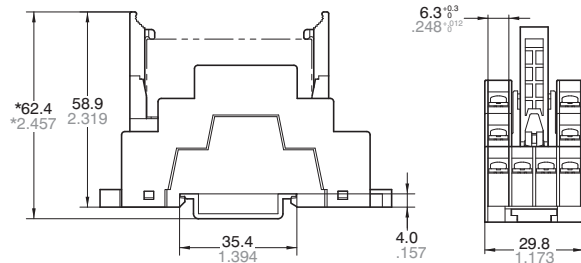

General tolerance: $\pm 0.5 \pm .020$

Schematic (Top view)

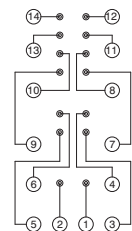

* Reference value (when using DIN rail ATA48011)

Note: Round terminals cannot be used with DIN terminal sockets.

REFERENCE DATA

1. Operate/response/release time
 Sample: SFS4-DC24V (4 Form A/2 Form B)
 Quantity: n = 20 (a contacts: 80, b contacts: 40)

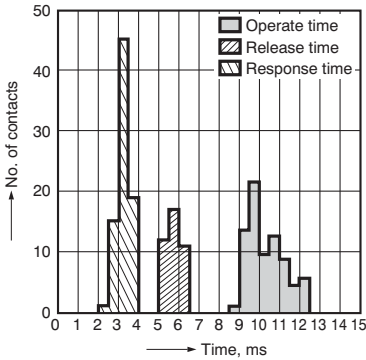

2. Coil temperature rise
 Sample: SFS4-DC24V (4 Form A/2 Form B)
 Quantity: n = 3
 Measured portion: Inside the coil
 Ambient temperature: Room temperature
 (27°C 80.6°F), 70°C 158°F, 85°C 185°F

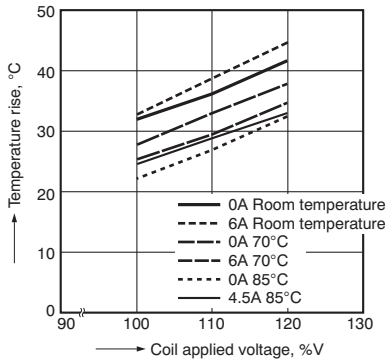

3. Malfunctional shock
 Sample: SFS4-DC24V (4 Form A/2 Form B)
 Quantity: n = 3

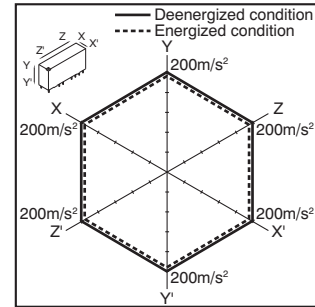

4. Max, switching capacity
 (2 Form A/2 Form B type)

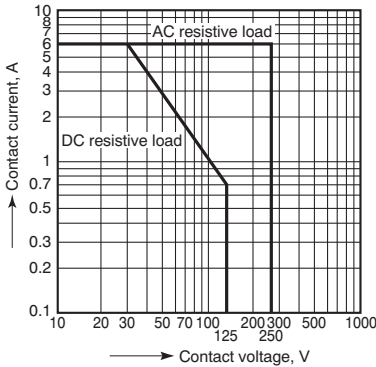

Other contact gaps when contacts are welded

Sample: SFS4-DC24V (4 Form A/2 Form B)
 The table below shows the state of the other contacts.
 In case of form “NO” contact weld the coil applied voltage is 0 V.
 In case of form “NC” contact weld the coil applied voltage is nominal.

		State of other contacts					
		3-4 (NC)	5-6 (NC)	7-8 (NO)	9-10 (NO)	11-12 (NO)	13-14 (NO)
Welded contact No.	3-4 (NC)			>0.5	>0.5	>0.5	>0.5
	5-6 (NC)			>0.5	>0.5	>0.5	>0.5
	7-8 (NO)	>0.5	>0.5				
	9-10 (NO)	>0.5	>0.5				
	11-12 (NO)	>0.5	>0.5				
	13-14 (NO)	>0.5	>0.5				

>0.5: contact gap is kept at min. 0.5 mm .020inch

Empty cells: either ON or OFF

Note: Contact gaps are shown at the initial state.

If the contact transfer is caused by load switching, it is necessary to check the actual loading.

SAFETY STANDARDS

Certification authority	File No.	
UL/C-UL	E43149*	6A 277V AC, 6A 30V DC
TÜV	B 05 04 13461 054	6A 250V AC (cosφ=1.0), 6A 250V DC (0ms), AC15: 2A 240V AC (cosφ=1.0), DC13: 1A 24V DC (L/R 48ms)

* CSA standard: Certified by C-UL

NOTES

1. Coil operating power

Pure DC current should be applied to the coil. The wave form should be rectangular. If it includes ripple, the ripple factor should be less than 5%. However, check it with the actual circuit since the characteristics may be slightly different.

2. Coil connection

When connecting coils, refer to the wiring diagram to prevent mis-operation or malfunction.

3. Cleaning

This relay is not sealed, therefore, immersion may cause failure. Be careful that flux does not overflow onto the PC board or penetrate inside the relay.

4. Soldering

When using automatic soldering, the following conditions are recommended

- 1) Preheating: 120°C 248°F, within 120 s max (PC board solder surface).
- 2) Soldering: 260°C±5°C 500°F±41°F, within 6 s max.

5. Attach directly to the chassis or use a DIN rail.

(1) When attaching directly to chassis

- Use a M3.5 screw, spring washer, and hex nut.
- For the mounting pitch, refer to the dimensions.

(2) When installing on a DIN rail

- Use a 35 mm 1.378 inch wide DIN rail (DIN46277).
- Install and remove as shown in the figures below.

<When installing>

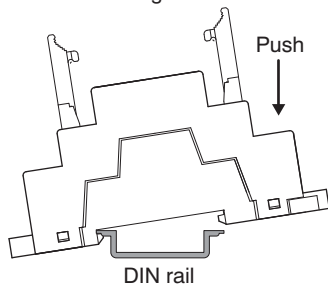

<When removing>

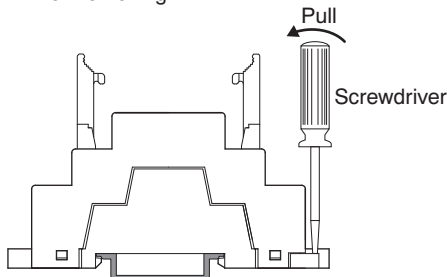

2) Refer to the figure below for applicable wire-pressed terminals. (You cannot use round type wire-pressed terminals.)

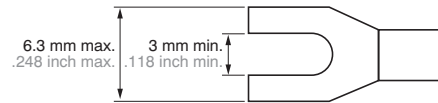

6. Other

1) If the relay has been dropped, the appearance and characteristics should always be checked before use.
2) The switching lifetime is defined under the standard test condition specified in the JIS* C 5442-1996 standard (temperature 15 to 35°C 59 to 95°F, humidity 25 to 75%). Check this with the actual product as it is affected by the coil driving circuit, load type, activation frequency, activation phase, ambient conditions and other factors. Also, be especially careful with loads such as those listed below.

(1) When used for AC load-operation and the operating phase is synchronous. Rocking and fusing can easily occur due to contact shifting.
(2) During high frequency on/off operation with certain loads, arcing may occur at the contacts. This can cause fusion to Oxygen and Nitrogen gas in the air creating Nitric Acid (HNO₃) which can cause corrosion to the contacts.

Please see the following countermeasure examples:

1. Incorporate an arc-extinguishing circuit.
2. Lower the operating frequency
3. Lower the ambient humidity

3) For secure operations, nominal coil voltage should be applied. In addition, please note that pick-up and drop-out voltage will vary according to the ambient temperature and operating conditions.

4) Heat, smoke, and/or fire may occur if the relay is used outside the allowable ranges for the coil ratings, contact ratings, operating cycle lifetime, and other specifications. Therefore, do not use the relay if these ratings are exceeded. Also, make sure that the relay is wired correctly.

5) Incorrect wiring may cause false operation or generate heat or flames.

6) Check the ambient conditions when storing or transporting the relays and devices containing the relays.

Freezing or condensation may occur in the relay causing damage. Avoid exposing the relays to heavy loads, or strong shock and vibration.

7. Usage, transport and storage conditions

1) Ambient temperature, humidity, and atmospheric pressure during usage, transport, and storage of the relay:

(1) Temperature:

–40 to +85°C –40 to +185°F

(When the temperature is 70 to 80°C, reduce the 6 A max. switching current by 0.1 A/°C.)

(2) Humidity: 5 to 85% RH

(Avoid freezing and condensation.) The humidity range varies with the temperature. Use within the range indicated in the graph below.

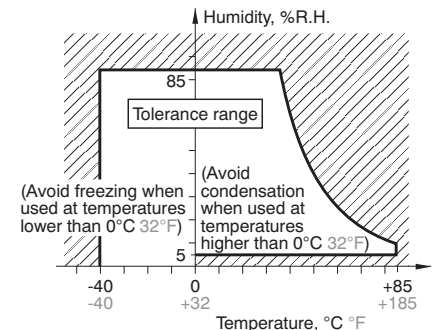

(3) Atmospheric pressure: 86 to 106 kPa

Temperature and humidity range for usage, transport, and storage

2) Condensation

Condensation forms when there is a sudden change in temperature under high temperature and high humidity conditions. Condensation will cause deterioration of the relay insulation.

3) Freezing

Condensation or other moisture may freeze on the relay when the temperatures is lower than 0°C 32°F. This causes problems such as

sticking of movable parts or operational time lags.

4) At low temperature, low humidity environments, the plastic becomes brittle.

Please note corrections.

8. Please connect DC coil types with LED and built-in diode correctly by verifying the coil polarity (“+” and “-”). Connecting with reverse polarity will cause the LED not to light and damage the built-in diode due to its specification.

For Cautions for Use, see [Relay Technical Information](#).